

Cable glands

SKINDICHT® cable glands plastic or metal metric
SKINDICHT® Angle cable glands

SKINDICHT® KW-M

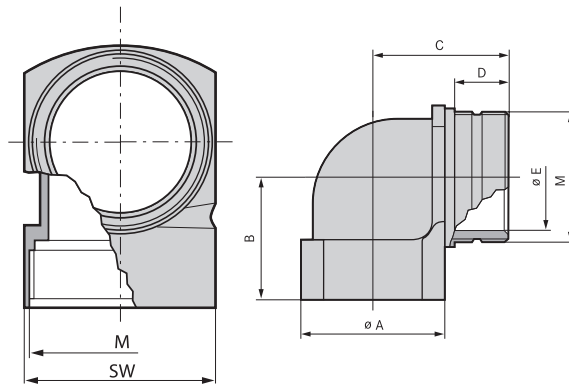

SKINDICHT® KW-M

■ Benefits

- Saving space
- Decrease of installation height

■ Application range

- Angle glands are used wherever cables have to run in parallel to the housing wall.
- Light and sound applications
- Switch cabinet building

■ Approvals (Norm references)



■ Design

- Metric connection thread acc. to EN 50262

■ Note

- For suitable O-rings, see SKINDICHT® O-ring Perbunan®
- SKINDICHT® KW-M can be combined with any cable gland, in particular with SKINTOP® ST-M.
- Counter nut to be used SKINTOP® GMP-GL-M

■ Technical data

	Colour delivered RAL 7001 silver grey
	Material Polyamide, glass fibre reinforced
	Degree of protection IP 55
	Range of temperature -20°C up to +80°C

Part number	Part designation / size	A mm	B in mm	ØE mm	SW mm	Overall length C mm	Thread length D mm	Pieces / PU
SKINDICHT® KW-M								
52106210	16 x 1,5	19.0	21.5	11	19	24.0	13.0	25
52106220	20 x 1,5	25.0	24.5	15	25	29.5	15.0	25
52106230	25 x 1,5	30.0	28.0	20	30	33.5	16.0	25
52106240	32 x 1,5	36.0	31.5	26	36	38.0	17.0	10

Perbunan® is a registered trademark of BAYER AG